



**MITHRA
FUELING**



MITHRA

Solid

Flexible and adjustable

Efficient long life

Exclusively manufactured
for the environmental
conditions of Iraqi Market



RETAIL AND COMMERCIAL FUEL DISPENSING SOLUTIONS

WWW.MITHRAFUELING.COM

Solid and durable Mithra series fuel dispensers are designed for optimum durability. It has a long-lasting and powerful hydraulic structure with full flexibility at different flow rates and configurations.

The Mithra series fuel dispensers are also biofuel and ethanol compatible, safe and have a special interface and are compatible with automation systems. It is the perfect solution for both your retail and commercial applications.

MITHRA SERIES FUEL DISPENSERS

Reliable Mithra fuel dispensers offer a quality construction with a solid structure for high strength. Protection and powder coated steel metal panels protect the dispenser from all weather conditions and scratches. In addition to high-quality hoses and nozzles, we ensure the durability of our products by using best-in-class components in all Mithra's dispenser series.

Flexible and adaptable to many configurations, our Mithra series fuel dispensers offer complete flexibility with different flow rates, hose and biofuel compatibility. It supports all the leading communication protocols with proven, state-of-the-art innovative electronics and is compatible with most fleet management systems.

Mithra series fuel dispensers know the value for your money and use a special interface and meter encoder. With its ergonomic hose and hanger structure, superior integrated and backlit display and ease of maintenance, the Mithra series dispenser offers ease of use and low total cost of ownership.

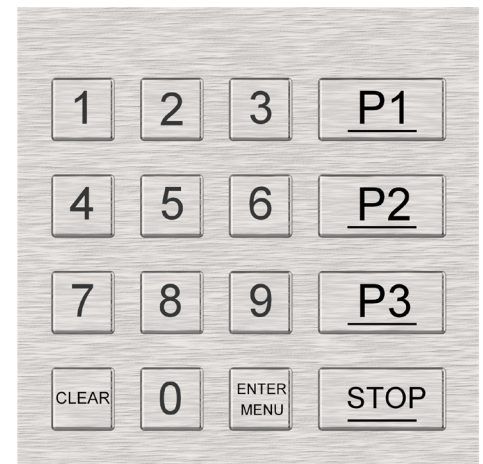



**MITHRA 224
FUEL DISPENSER**



**MITHRA 224 HF
FUEL DISPENSER**



**MITHRA 244
FUEL DISPENSER**



**MITHRA 224 UHF
FUEL DISPENSER**

**MITHRA 122
LPG DISPENSER**



**MITHRA 364
FUEL DISPENSER**



MITHRA DISPENSER DIMENSIONS

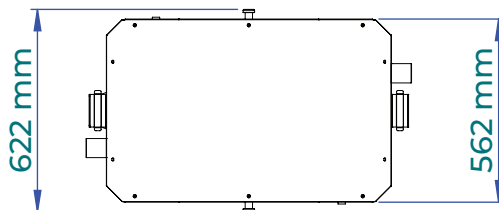
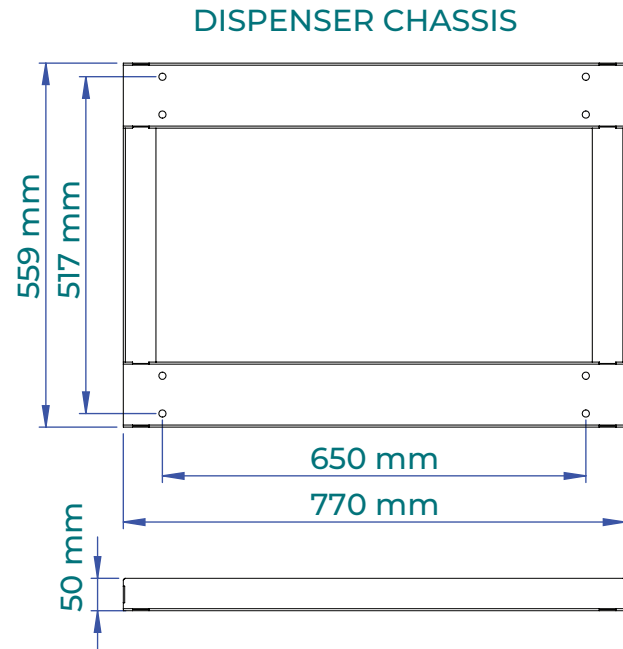
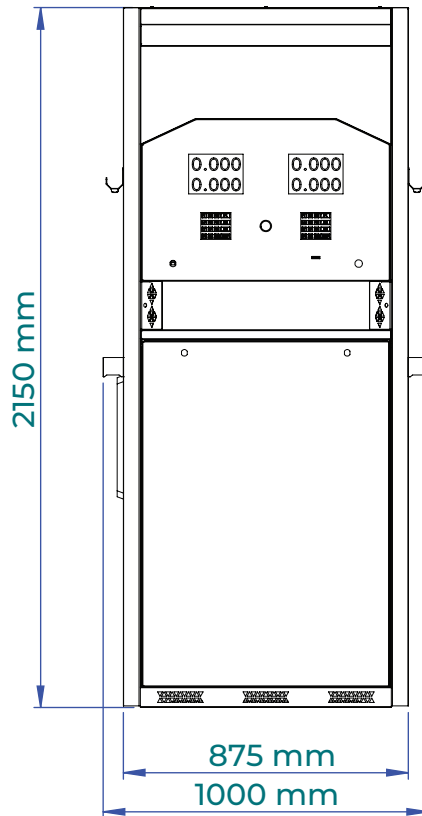

RETAIL AND COMMERCIAL FUEL DISPENSING SOLUTIONS

Mithra compact and robust Mithra fuel dispensers are designed for optimum durability. It has powerful hydraulics for operations in difficult conditions, with full flexibility in different flow rates and configurations.

The Mithra is also biofuel and ethanol compatible, it is safe and has a special interface and a meter encoder. It is an excellent solution for both retail and commercial applications.

THE SAFEST IN IT'S CLASS

Increase your control and give your users exclusive access. Safe entry with the latest technology means that electronic Mithra fuel dispensers can. Provide many levels of access, so you can easily manage who controls what. A wired keypad provides stable and safe secure access.

Electronic calibration means quick diagnostics and quick service. Get acquainted with Mithra fuel dispenser solutions to reduce the downtime of service facilities in the field. You will notice its technology and durability in a short time.

You can optionally customize the appearance of the Mithra fuel dispensers with an attractive and durable body to fit your fuel station with the option of a stainless-steel body and hydraulic panels.

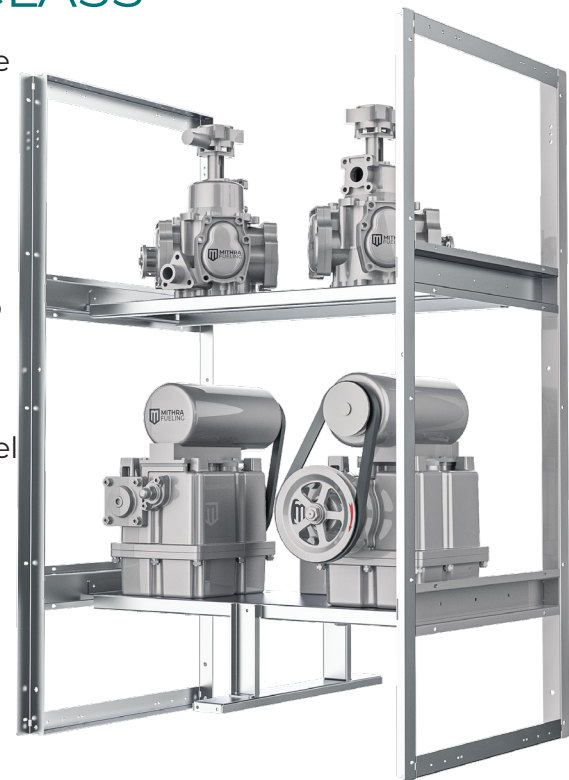

RETAIL AND COMMERCIAL FUEL DISPENSING SOLUTIONS

AUTOMATION SYSTEM READY



RETAIL AND COMMERCIAL FUEL DISPENSING SOLUTIONS

TECHNICAL SPECIFICATIONS

Standard Features

- 1 or 2 Product with up to 2 hoses and 4 displays (2 fuelling positions)
- LCD displays with LED resistance against sunlight
- Petrol, Benzene, Benzene 97, Diesel, Kerosene
- Mithra pumping unit flow rate 35-55 lpm
- Mithra pumping unit flow meter accuracy 0.25%
- Powder coated steel housing
- High quality hanging hardware
- Pipe hook
- Secure Interface Pulser
- 7 digit electro mechanical non-resettable totalisers
- Solenoid valve 0.3 ~ 6 bar

Options

- High flow (100 LPM) and ultra high flow (180 LPM) capacities
- Low temperature hose and nozzles
- Optional heater for below -30°C
- Enhanced corrosion protection
- Automatic temperature compensation



RETAIL AND COMMERCIAL FUEL DISPENSING SOLUTIONS

Mithra Dispensers

Motor 3 Phase	400V, 50 Hz / 60Hz
Meter Unit	Mithra positive displacement meter with electronic calibration
Pumping Unit	Mithra gear or vane type pumping unit
Electronics	Mithra Innovator EFSC +
Communication Protocol	Mithra Dart - 2 Wire RS-485
Environmental	-30°C to +70°C
Approvals	ATEX, MID, CE, ISO, INTERTEK
Standard Flowrate	45 LPM
High Flowrates	100 LPM
Ultra High Flowrates	180 LPM

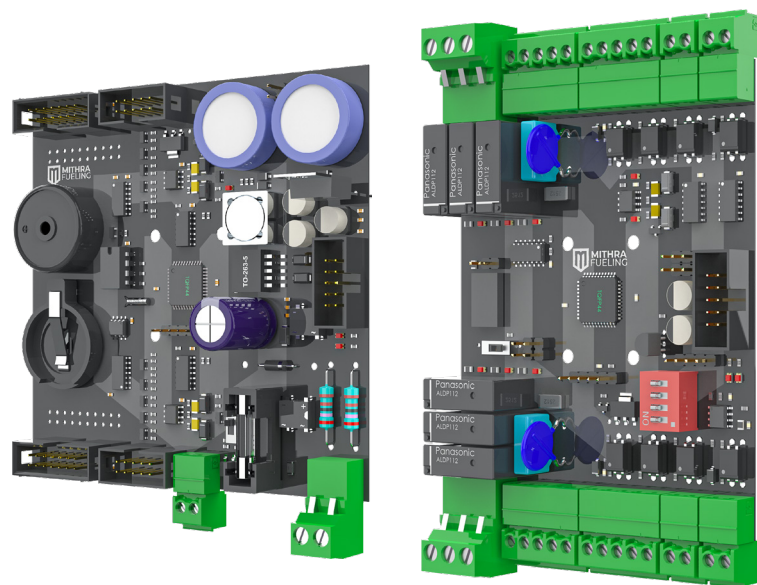

EFSC+ CPU CONFIGURATION DIAGRAM

EFSC+ CPU	
CONFIGURATION DIAGRAM	
PRODUCT: 1-5	
NOZZLE: 1-10	
FILLING POINT :1-2	

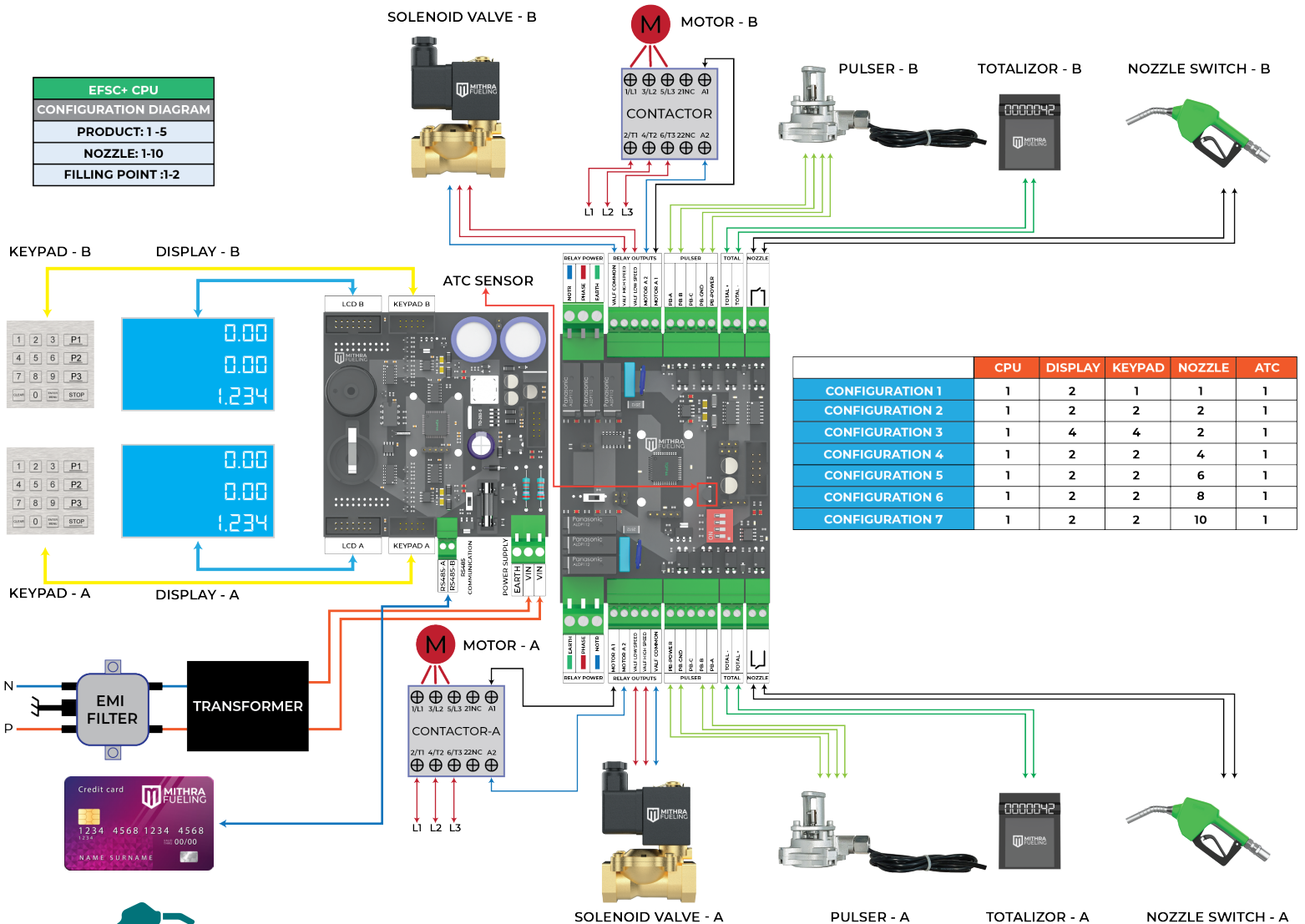

	CPU	DISPLAY	KEYPAD	NOZZLE	ATC
CONFIGURATION 1	1	2	1	1	1
CONFIGURATION 2	1	2	2	2	1
CONFIGURATION 3	1	4	4	2	1
CONFIGURATION 4	1	2	2	4	1
CONFIGURATION 5	1	2	2	6	1
CONFIGURATION 6	1	2	2	8	1
CONFIGURATION 7	1	2	2	10	1





Your style of dispenser, because we can...

With 20 years of experience in the fuel industry, we perfectly understand the fuel needs of your business.

The Mithra brand stands for quality, development, innovation and seamless integration, and we are ready to help you develop your business.

To learn more about any of our fuel technologies, please contact us or visit our website.

